

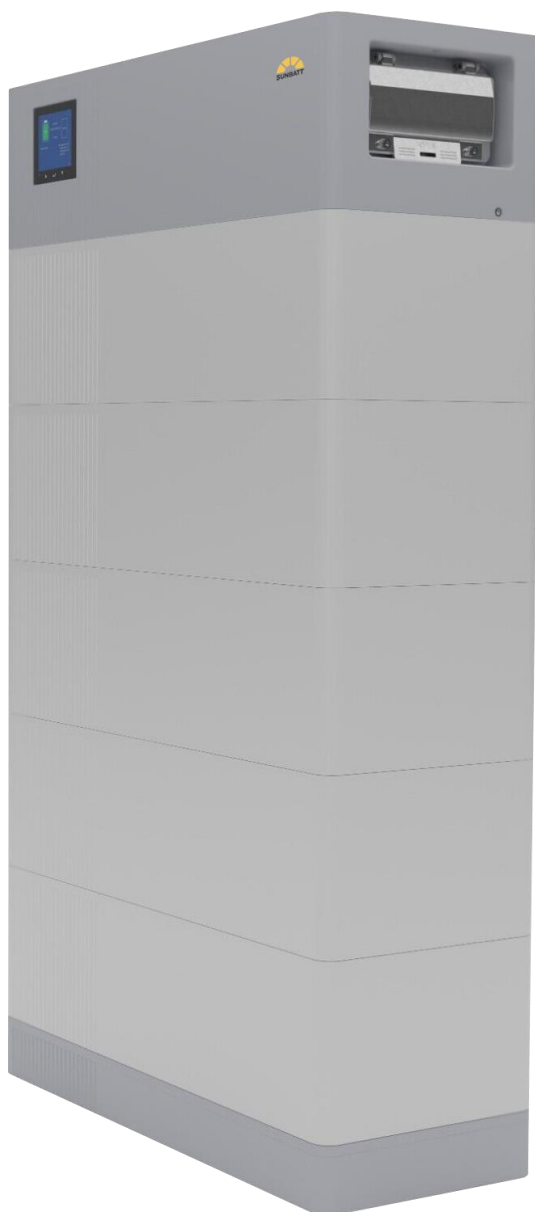

Sunbatt

Operating Manual

Version 1.0



Legal Provisions

All the information in this document is the property of Sunbatt Europe SL. No part of this document could be reproduced in any way for business use. Internal use is allowed.

Sunbatt Europe SL makes no representations or warranties express or implied, with respect to this document or any of the equipment and/or software it may describe, including (with no limitation) any implied warranties of utility, merchantability, or fitness for any particular purpose. All such representations or warranties are expressly disclaimed. Neither Sunbatt Europe SL nor its distributors or dealers shall be liable for any indirect, incidental, or consequential damages under any circumstances.

The exclusion of implied warranties may not apply in all cases under some statutes, and thus the above exclusion may not apply.

This document does not replace and is not intended to replace any local, state, provincial, federal, or national laws, regulations, or codes applicable to the installation, electrical safety, and use of the battery system. Sunbatt Europe SL assumes no responsibility for compliance or noncompliance with such laws or codes in connection with the installation of the battery system.

Specifications are subject to change without notice. Every effort has been made to make this document complete, accurate, and up-to-date. However, Sunbatt Europe SL may need to make some improvements under certain circumstances without advance notice. Sunbatt Europe SL shall not be responsible for any loss caused by this document, including, but not limited to commissions errors, typographical errors, arithmetical errors, or listing errors in this document.

All trademarks are recognized.

Limited Warranty

You can download the latest Limited Warranty from the Internet at: www.sunbatt.eu

Sunbatt Europe SL

c/ Arboleda 18, 28031, Madrid, Spain

Legal Provisions	3
1. Information on this Document	6
1.1. Validity	6
1.2. Target Group	6
1.3. Content and Structure of this Document	6
1.4. Declaration of Conformity	6
1.5. Levels of Warning Messages	7
1.6. Symbols in the Document	7
1.7. Designation in the Document	7
2. Safety	8
2.1. Intended Use	8
2.2. IMPORTANT SAFETY INSTRUCTIONS	9
2.2.1. Battery Stack Leakage	9
2.2.2. Firefighting Measures	10
2.2.3. Battery Stacks Handling and Storage Guide	10
2.2.4. Warning of Electric Shock	11
2.2.5. Warning of Overvoltage	11
2.2.6. Caution of Weight	12
2.2.7. Notice of Property Damage	12
3. Scope of Delivery	13
4. Battery System Overview	14
4.1. Battery System Description	14
4.2. LCD Display Description	15
4.2.1. Settings	16
4.2.2. LED Indicator	17
4.2.3. Status	18
4.2.4. Comm Cable Status	19
4.3. Symbols on the System	19
5. Installation	21
5.1. Requirements for Installation	21
5.1.1. Requirements for Installation Location	21
5.1.2. Tools	22
5.1.3. Safety Gear	24
5.1.4. Additional Required Installation Materials	25
5.2. Installation	26

6. Electrical Connection	28
6.1. Overview of the Connection Area	28
6.2. Connection Diagram	29
6.2.1. Single Tower	29
6.2.2. Multiple Towers	29
6.3. Connecting the Grounding Conductor	30
6.4. Data Cable Connection	31
6.4.1. Fit RJ45 Connector into the Coupler	31
6.4.2. Connect the Data Cable to an Inverter	32
6.4.3. Connect to the Router	33
6.4.4. Parallel Connection between Towers	34
6.5. DC Connection	36
7. Commissioning	38
7.1. Switch on Inverter AC Power Supply and Do Configuration	38
7.2. Switch on the Battery System	38
7.3. Configure the Settings on the LCD Display	39
7.4. Close up	40
8. Operation	41
8.1. Switch on the Battery System	41
8.2. Switch off the Battery System	42
9. Decommissioning	43
9. Decommissioning	44
10. Extension	45
11. Troubleshooting	46
12. Maintenance and Storage	47
13. Disposal of the Battery System	48
14. Technical Data	49
15. Contact Information	51

1.1. Validity

This document is valid for the Sunbatt Peak and Flex.

1.2. Target Group

The instructions in this document may only be performed by qualified persons who must have the following skills:

- Knowledge of how batteries work and are operated
- Knowledge of how an inverter works and is operated
- Knowledge of, and adherence to the locally applicable connection requirements, standards, and directives
- Knowledge of, and adherence to this document and the associated system documentation, including all safety instructions
- Trained in dealing with the hazards associated with the installation and operation of electrical equipment and batteries
- Trained in the installation and commissioning of electrical equipment

Failure to do so will make any manufacturer's warranty, guarantee or liability null, and void unless you can prove that the damage is not due to non-compliance.

1.3. Content and Structure of this Document



This document contains safety information and instructions, scope of delivery, system overview, installation, electrical connection, commissioning, decommissioning, expansion, troubleshooting, maintenance and storage, disposal, and technical data. Please finish reading this document before taking any action on the battery system.

1.4. Declaration of Conformity

The battery system described in this document complies with the applicable European directives. The certificates are available in the download area at: www.sunbatt.eu

1.5. Levels of Warning Messages

The following levels of warning messages may occur when handling the battery system.

 DANGER
Indicates a hazardous situation which, if not avoided, will result in death or serious injury.
 WARNING
Indicates a hazardous situation which, if not avoided, could result in death or serious injury.
 CAUTION
Indicates a hazardous situation which could result in minor or moderate injury.
NOTICE
Indicates a situation which, if not avoided, could result in property damage.

1.6. Symbols in the Document

 QUALIFIED PERSON	Sections with this symbol indicates actions only to be performed by qualified persons.
-------------------------------------------------------------------------------------------------------------	----------------------------------------------------------------------------------------

1.7. Designation in the Document

Designation in this document	Complete designation
Battery System	Sunbatt Peak and Sunbatt Flex
BMS	Battery Management System
Sunbatt Europe SL	Sunbatt
SOC	State of Charge

2.1. Intended Use

The battery system is for residential use and works with a photovoltaic system. It is a high-voltage Li-ion battery storage system, with the control unit on itself. It could be operated in on-grid, off-grid and backup modes with a compatible inverter.

The battery system could be connected to the Internet through a network cable for maintenance and firmware updating.

The battery system must only be used as stationary equipment.

The battery system is suitable for indoor and outdoor use under the conditions mentioned in Section 5.1.

The battery system must only be operated in connection with a compatible inverter.

The battery system is not suitable for supplying life-sustaining medical devices. Please ensure that no personal injury would occur due to the power outage of the battery system.

Alterations to the battery system, e.g., changes or modifications are not allowed unless the written permission of Sunbatt is achieved. Unauthorized alterations will void the guarantee and warranty claims. Sunbatt shall not be held liable for any damage caused by such changes.

The type label should always be attached to the battery system.

2.2. IMPORTANT SAFETY INSTRUCTIONS

The battery system has been designed and tested in accordance with international safety requirements. However, in order to prevent personal injury and property damage and ensure the long-term operation of the battery system, please do read this section carefully and observe all safety information at all times.

2.2.1. Battery Stack Leakage

If the battery stacks leak electrolytes, contact with the leaking liquid or gas should be avoided. The electrolyte is corrosive, and the contact may cause skin irritation and chemical burns. If one is exposed to the leaked substance, please perform the following actions:

Inhalation: Evacuate the contaminated area, and seek medical help immediately.

Eye contact: Rinse eyes with flowing water for 15 minutes and seek medical help immediately.

Skin contact: Wash the affected area thoroughly with soap and water and seek medical help immediately.

Ingestion: Induce vomiting and seek medical help immediately.

2.2.2. Firefighting Measures

The battery stacks may catch fire when it is put into the fire. In case of a fire, please make sure that an ABC or carbon dioxide extinguisher is nearby. Water cannot be used to extinguish the fire.

Full protective clothing and self-contained breathing apparatus are required for the firefighters to extinguish the fire.

2.2.3. Battery Stacks Handling and Storage Guide

- The battery stacks and their components should be protected from damage when transporting and handling.
- Do not impact, pull, drag, or step on the battery stacks.
- Do not insert unrelated objects into any part of the battery stacks.
- Do not throw the battery stack into the fire.
- Do not soak the battery stacks in water or seawater.
- Do not expose the battery stacks to strong oxidizers.
- Do not short-circuit the battery stacks.
- The battery stacks cannot be stored at high temperatures (more than 55 °C).
- The battery stacks cannot be stored directly under the sun.
- The battery stacks cannot be stored in a high humidity environment.
- Do not use the battery stacks if they are defective, or appear cracked, broken or otherwise damaged, or fail to operate.
- Do not attempt to open, disassemble, repair, tamper with, or modify the battery stacks. The battery stacks are not user-serviceable.
- Do not use cleaning solvents to clean the battery stacks.

2.2.4. Warning of Electric Shock



DANGER

Danger to life due to electric shock when live components or DC cables are touched

The DC cables connected to an inverter may be live. Touching live DC cables results in death or serious injury due to electric shock.

- Disconnect the battery system and inverter from voltage sources and make sure it cannot be reconnected before working on the device.
- Do not touch non-insulated parts or cables.
- Do not remove the terminal block with the connected DC conductors from the slot under load.
- Wear suitable personal protective equipment for all work on the battery system.
- Observe all safety information of the inverter manufacturer.

2.2.5. Warning of Overvoltage



DANGER

Danger to life due to electric shock in case of overvoltage and if surge protection is missing

Overvoltage (e.g. in the event of a flash of lightning) can be further conducted into the building and to other connected devices in the same network via the network cables or other data cables if there is no surge protection. Touching live parts and cables results in death or lethal injuries due to electric shock.

- When laying the network cables or other data cables outdoors, it must be ensured that a suitable surge protection device is provided at the transition point of the cable from the battery system or the inverter outdoors to the inside of a building.

2.2.6. Caution of Weight

CAUTION

Risk of injury due to the weight of the battery stack

Injuries may occur if the battery stack is lifted incorrectly or dropped while being transported or installed.

- Transport and lift the battery stack carefully. Take the weight of the battery stack into account.
- Wear suitable personal protective equipment for all work on the battery system.

2.2.7. Notice of Property Damage

NOTICE

Damage to the BMS due to sand, dust and moisture ingress

Sand, dust and moisture penetration can damage the BMS and impair its functionality

- Only open the BMS if the humidity is within the thresholds and the environment is free of sand and dust.

3. Scope of Delivery

BMS and Base Package

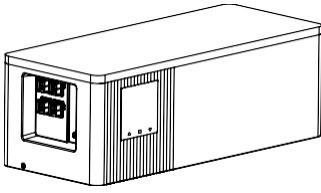

1 - BMS

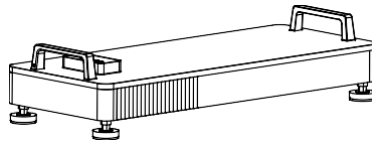

1 - Base

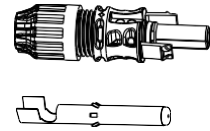

1 - Female power cable coupler

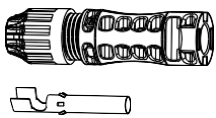

1 - Male power cable coupler

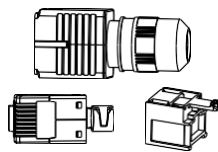

4 - Network cable coupler

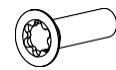

2 - Screw (M4x16)

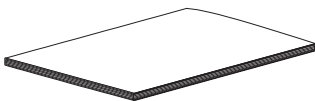

1 - Documents

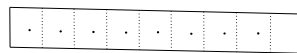

1 - Drilling template

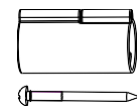

2 - Protection sleeve for power cable connector

Battery Stack Package

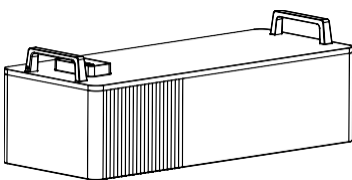

1 - Battery stack

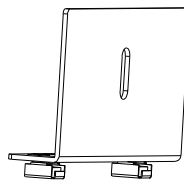

1 - Hanger

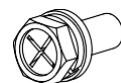

2 - Screw (M6x16)

4.1. Battery System Description

The Sunbatt Peak and Flex is used as a connected battery for the intermediate storage of excess PV energy in an inverter system.

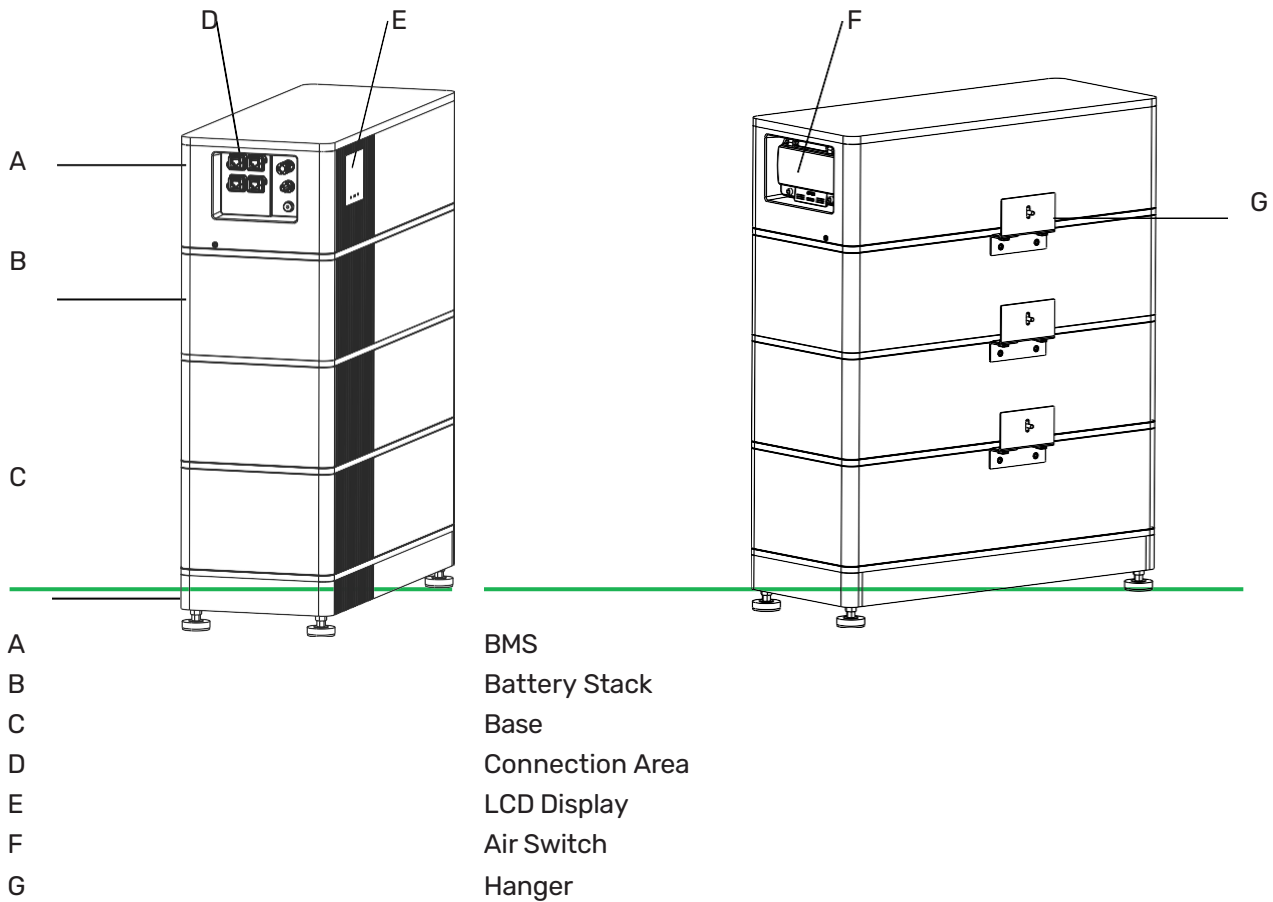

BMS, short for Battery Management System, is the control unit of the battery system.

There are two types of battery stacks, The former one has a higher rated power while the latter one has a higher rated usable energy.

Two to five Sunbatt Peak battery stacks or three to eight Sunbatt Flex battery stacks could be installed in one tower, and maximum of six battery towers could be connected in parallel.

These two battery stacks cannot be mixed up in operation.

4.2. LCD Display Description

In the display of the product, you can read the status of the product, and adjust settings.

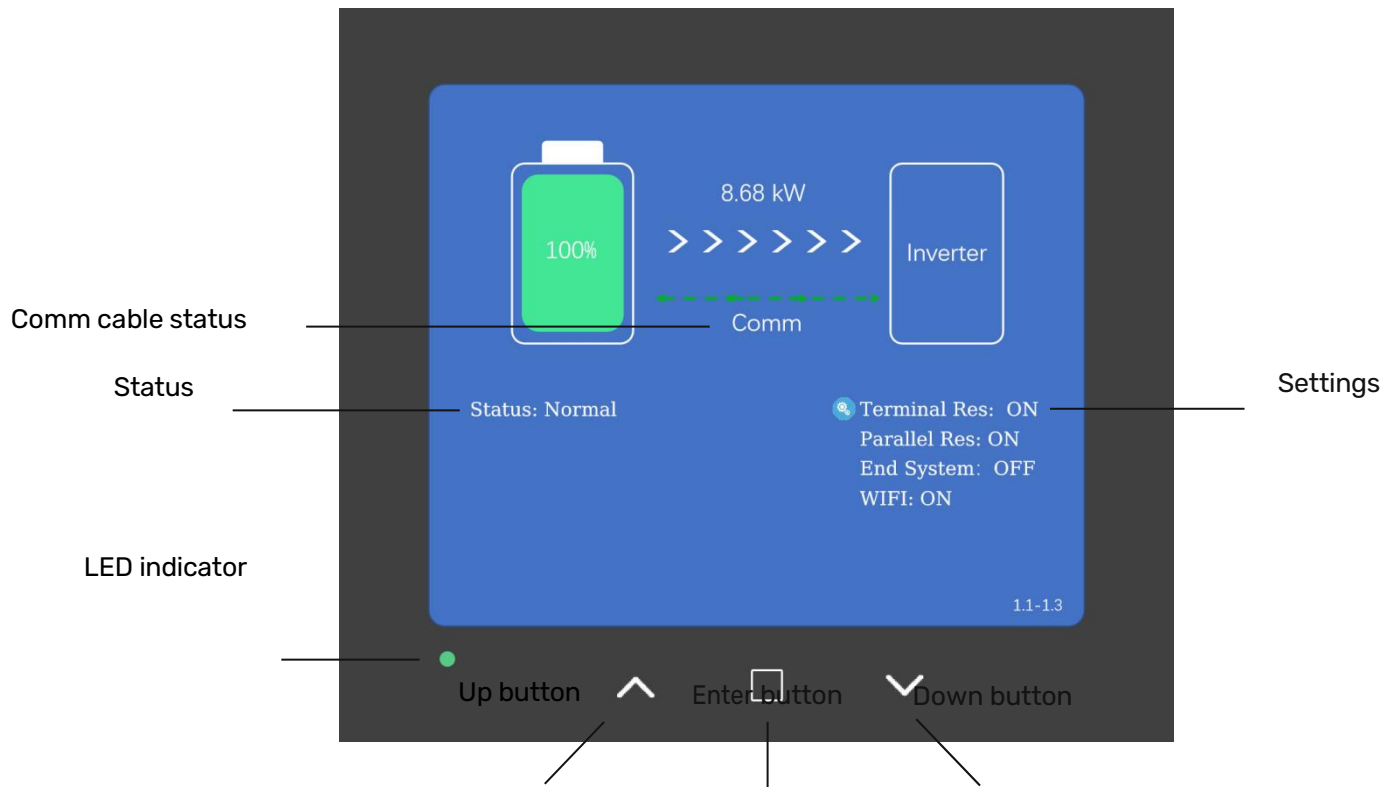

4.2.1. Settings

Five settings could be adjusted.

Terminal Res

Terminal Res means the terminal status for the communication circuit with the inverter.

The default status is "ON".

No need to adjust for slave towers.

Parallel Res

Parallel Res means the terminal resistors in the communication circuit of BMSes which are connected in parallel.

The default status is "ON".

End System

End System means there is no tower coming after. The status "ON" means this tower is the last slave tower of the whole system.

The default status is "OFF".

If the status is not set correctly, the product may not operate properly.

Wi-Fi

The product is equipped with Wi-Fi as standard. The Wi-Fi will turn on as default after the battery switches on, but it will turn off automatically in 5 hours. You can activate the Wi-Fi again here.

The password of the Wi-Fi can be read on the last page of the Quick Start Guide, and also the sticker on the BMS near the air switch.

After downloading CORE Link+ (laptop), and connecting your devices to the product Wi-Fi, you can update the product firmware and read more detailed product information.

CORE Link + is available on the website. The default status is "ON".

Black-Start

Black-Start is used to start up an inverter when there is a power outage.

Keep pressing the Down button, and it will be shown.

The default status is "OFF".

Default Set

The default status is "ON".

Method of adjusting the settings:

1. Press the Enter button to show the Setting menu.
2. Press the Enter button again to change the status between the Up button and the Down button.
3. Press the Up button and the Down button to choose different parameters.

4.2.2. LED Indicator

The definition of the LED status could be read in the table below.

1	Initializing	Flashing green quickly (0.5 s interval)	Flashing
2	Idle	green slowly (1.0 s interval)	Steady green
3	Working	Steady yellow	
4	Error		







4.2.3. Status The status and errors can be read here. You can read the meaning of the status in the table below.

1001/2001	BTVH	The total voltage is too high.
1002/2002	BTVL	The total voltage is too low.
1003/2003	CVH	The cell voltage is too high.
1004/2004	CVL	The cell voltage is too low.
1005/2005	CTH_C	The cell temperature while charging is too high.
1006/2006	CTL_C	The cell temperature while charging is too low.
1007/2007	CTH_D	The cell temperature while discharging is too high.
1008/2008	CTL_D	The cell temperature while discharging is too low.
1009/2009	OC_C	Overcurrent occurs in charging.
1010/2010	OC_D	Overcurrent occurs in discharging.
1011/2011	CUB	The cell is in a serious unbalanced condition.
1014/2014	ENV_OT	The environment temperature is too high.
1016/2016	SecAla	Security alarm.
1101/2101	MemF	Memory fault.
1102/2102	VSF	Voltage sensor failed.
1103/2103	TSF	Temperature sensor failed.
1104/2104	BICcomF	Multiple BIC failed.
1105/2105	BVSF	Battery voltage sensor failed.
1106/2106	CSF	Current sensor failed.
1107/2107	R1F	Relay 1 (Anode) failed.
1109/2109	PreCCF	Pre-charge circuit failed.
1113/2113	SOHL	Cycle life fault (Low SOH or the failure of battery cell).
1201/2201	MSOFF	Air switch off
1208/2208	SCAla	Short-circuit alarm.
1301/2301	PamInc	The parameter is incorrect.
1302/2302	MTw	The stack type is wrong.
1303/2303	MNInc	The number of parallel stacks is inconsistent.
1304/2304	CANCOMF	Interior CAN communication fault.
1306/2306	invComTO	Inverter communication timeout.
1307/2307	IDDstF	BMS ID distribution failed.
1308/2308	BIC_com_F_S	Single BIC failed
1309/2309	PreCF	Pre-charge failed.
1310/2310	UPdF_int	The update of built-in systems (BMS/Parameter) failed.









4.2.4. Comm Cable Status

The line will be yellow when the communication with an inverter is initiated. It will change to green when the communication is established. When the color turns orange, and also shows "Comm fails", it means the communication is disrupted.

4.3. Symbols on the System

Symbol	Explanation
	Observe the documents Observe all documents supplied with the system.
	Grounding conductor This symbol indicates the position for connecting a grounding conductor.
	Disposal Do not dispose of the system together with household waste, Please contact Sunbatt service team (contact information at the end of this document) to dispose of it in accordance with regulations for electronic waste and used batteries.
	CE marking The system complies with the requirements of the applicable EU directives.
	This side up.
	Handle with care

4. Battery System Overview

Symbol	Explanation
	Keep dry.
	Keep the battery stacks away from open flame or ignition sources.
	Beware of electrical voltage.
	Beware of a danger zone This symbol indicates that the system must be additionally grounded if additional grounding or equipotential bonding is required at the installation site.
	Keep the battery stacks away from children.
	RCM (Regulatory Compliance Mark), a brief guide to electrical equipment approvals in Australia
	Do not short-circuit.
	The product has been tested and certified by TUV Rheinland.

5.1. Requirements for Installation

5.1.1. Requirements for Installation Location

- a) A solid support surface must be available (e.g., concrete or masonry).
- b) The installation location must be inaccessible to children.
- c) The installation location must be suitable for the weight and dimensions of the battery system.
- d) The installation location must not be exposed to direct solar irradiation.
- e) The installation location must not be close to the fire.
- f) The altitude of the installation location should be less than 3000m.
- g) The ambient temperature should be between -10°C and $+55^{\circ}\text{C}$.
- h) The ambient humidity should be between 5%-95%.

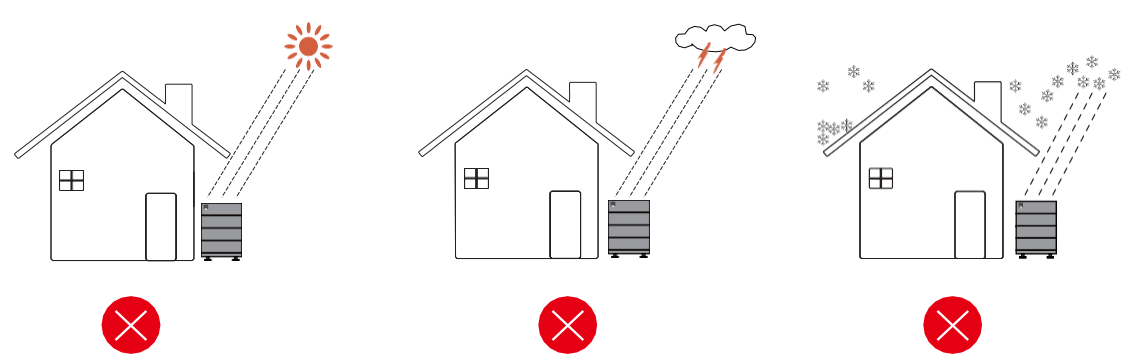
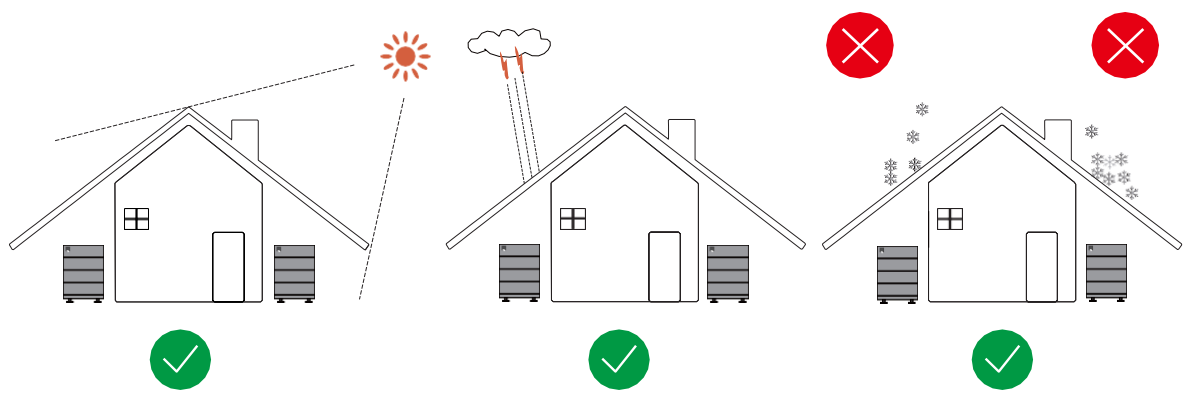
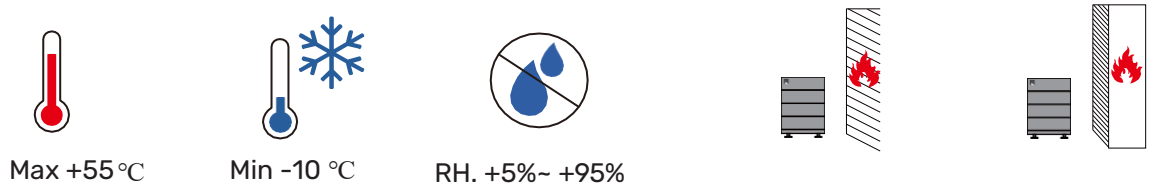

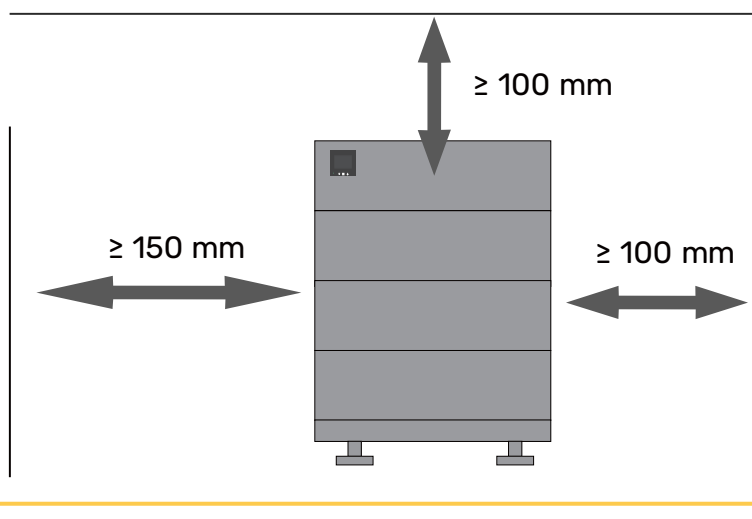

5.1.2. Tools

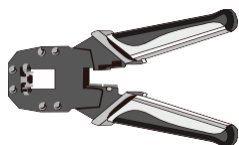

Network Wire Clamp

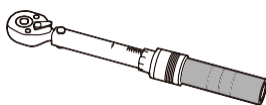

Torque Wrench

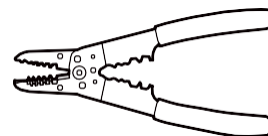

Wire Stripper



Wrench

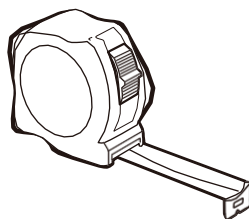

Tape Measure

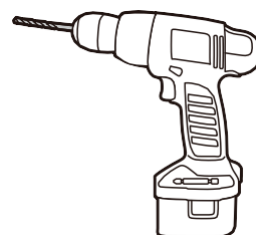

Drill



Torque Socket Wrench

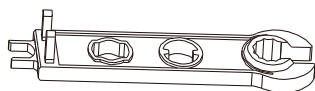

Power Cable Connector Tool
PV-MS-PLS

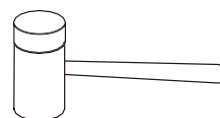

Rubber Mallet

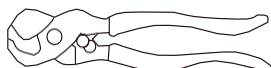

Cable Cutter

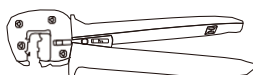

Crimping Tool
PV-CZM-42100

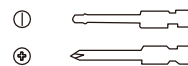

Screwdriver

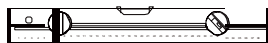

Lever



Marker

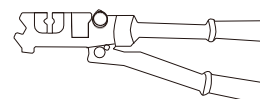

Hydraulic Pliers

5.1.3. Safety Gear

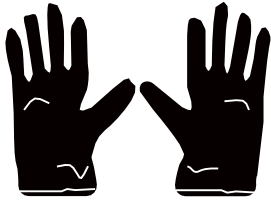

Safety Gloves

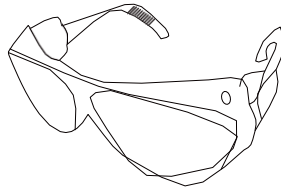

Safety Goggles

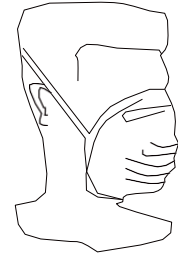

Dust Mask



Safety Boots

5.1.4. Additional Required Installation Materials

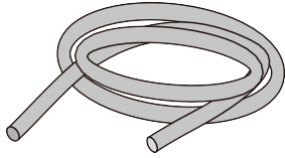

DC Cable

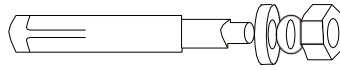

Expansion Bolt (M6)

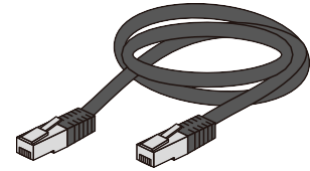

Network Cable
CAT 5 or higher, metal shielded



Grounding Cable

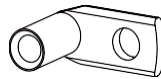

Right Cross Terminal

5.2. Installation

DANGER

Danger to life due to electric shock resulting from live DC cables or connectors in the battery system

The DC cables connected to the battery system may be live. Touching the DC conductors or the live components leads to lethal electric shocks.

- Do not touch non-insulated cable ends.

CAUTION

Risk of injury due to the weight of the battery stack

Injuries may occur if the battery stack is lifted incorrectly or dropped while being transported or installed.

- Transport and lift the battery stack carefully. Take the weight of the battery stack into account.
- Wear suitable personal protective equipment for all work on the battery system.

Additional required installation materials (not included in the scope of delivery):

- Screws suitable for the support surface (diameter: 6 mm)
- Where necessary, screw anchors suitable for the support surface and the screws.

Procedure:

1. Take out the BMS and base from the package.
2. Loosen the two screws (M4×16) with screwdriver T20.
3. Detach the BMS from the base.

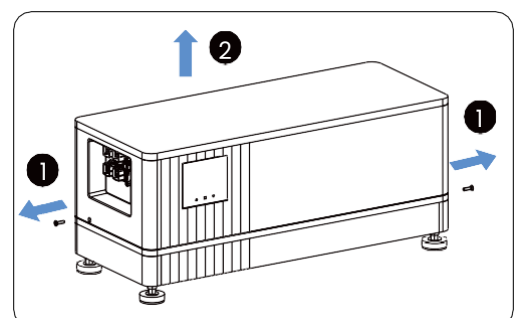

4. Put the base on the ground. Align the base with the wall surface and keep the edge of the base 26 mm to 32 mm away from the wall surface. Adjust the feet to make sure the base stands stable and the surface of the base is horizontal.
5. Align the bottom of the drilling template with the top surface of the base. And make sure that the hole of the template is between the central two screws on the base top surface.
6. Mark the drilling holes according to the quantity of stacks to be installed in one tower. Then remove the drilling template, drill holes and insert expansion bolt anchor. (When drilling holes, avoid the water pipes and power cables buried in the wall.)
7. Unpack the battery stack box, and pre-install the hanger on the wall with M6 expansion bolt nut. (no need to tighten them at this step)
8. Put the battery stack on the base, and then fasten the two screws between the hanger and the stack (torque: 5.5 Nm). And also fasten the hanger on the wall.
9. Repeat the procedures for other stacks.
10. Place the BMS on the top of the battery stack, press it down and check if the screw holes are aligned between the battery stack and the BMS.* Insert two screws (M4×16) into the holes, and tighten them (torque: 2.0 Nm) with a screwdriver (T20).
11. Mark the product type.

Note: * No more than 200 N.

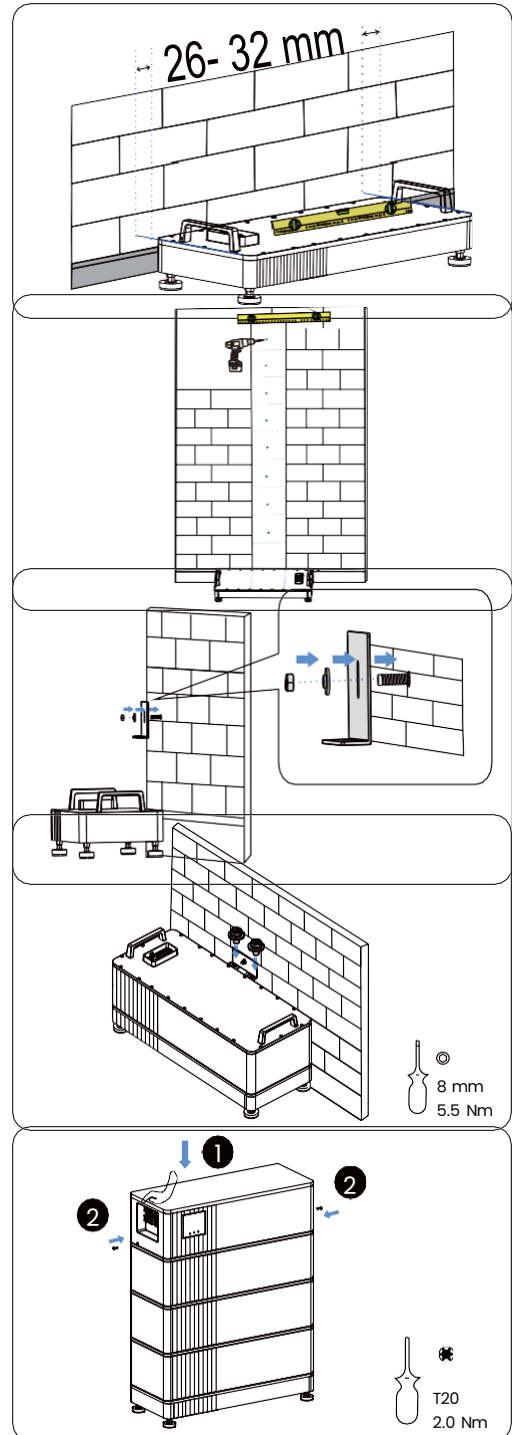

6.1. Overview of the Connection Area

Exterior view

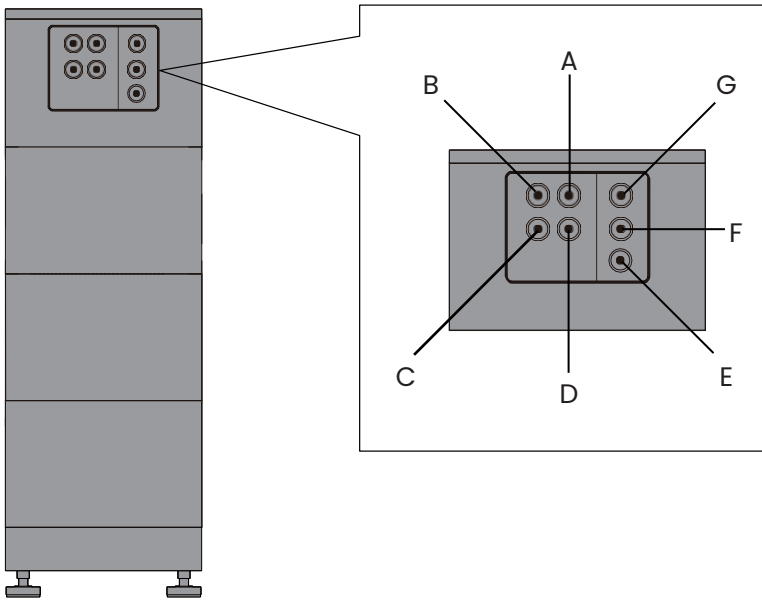

A	IN	IN port for parallel tower connection
B	OUT	OUT port for parallel tower connection
C	ETH	Network port for connecting a router or network switch
D	INV	Port for an inverter data cable
E	PE	Grounding cable connecting point
F	P-	DC- to inverter
G	P+	DC+ to inverter

6.2. Connection Diagram

6.2.1. Single Tower

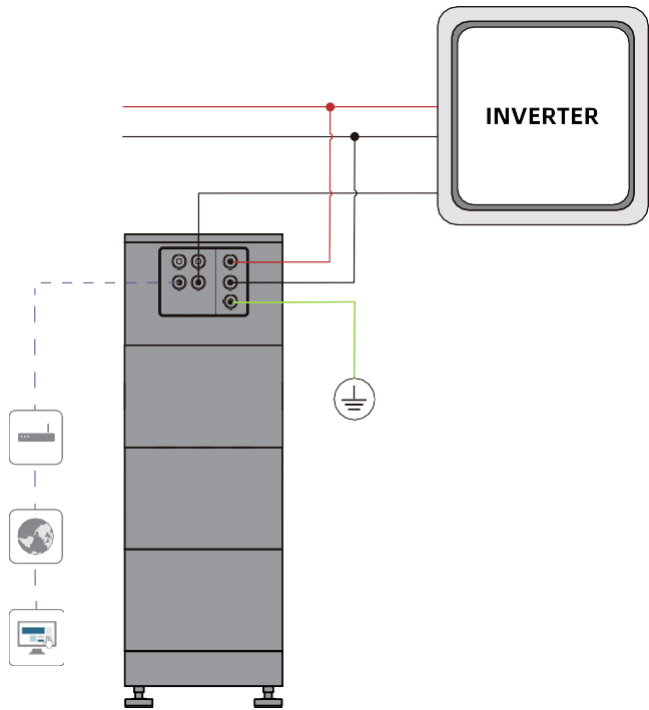

6.2.2. Multiple Towers

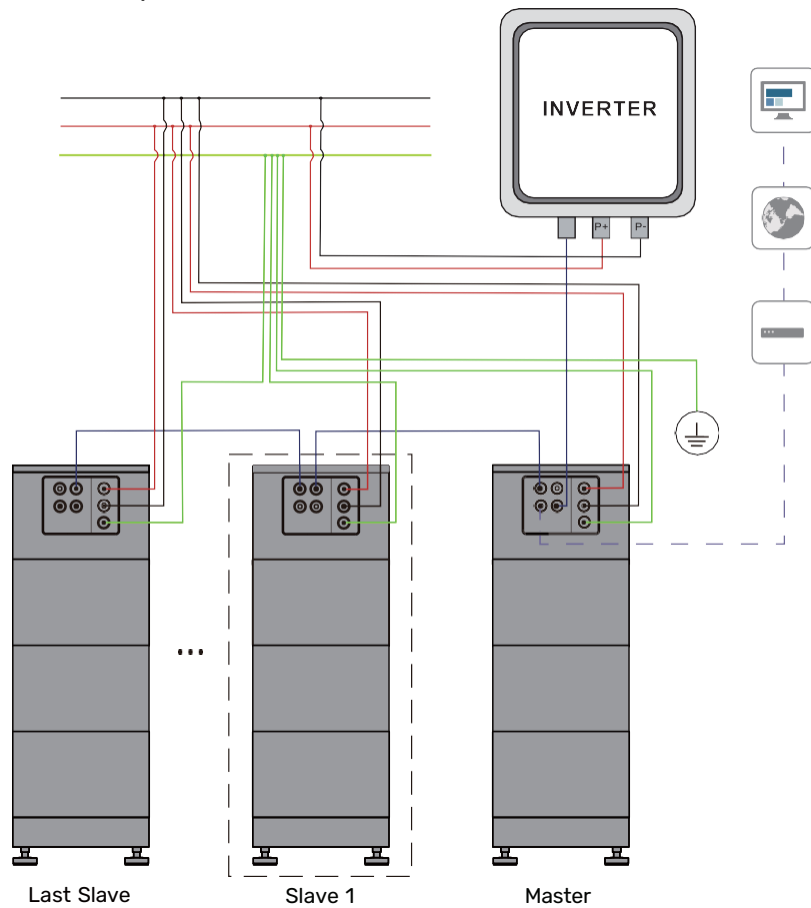

6.3. Connecting the Grounding Conductor



Additional required mounting materials (not included in the scope of delivery):

- a) Grounding cable cross-section: 10 mm²
- b) Conductor: 5mm, right angle type

Procedure:

1. Make sure the air switch of BMS is off.
2. Install the conductor on the grounding cable.
3. Remove the screw on port for grounding connector, put the cable there, and tighten it with the same screw (M4×8). (torque: 2 Nm).

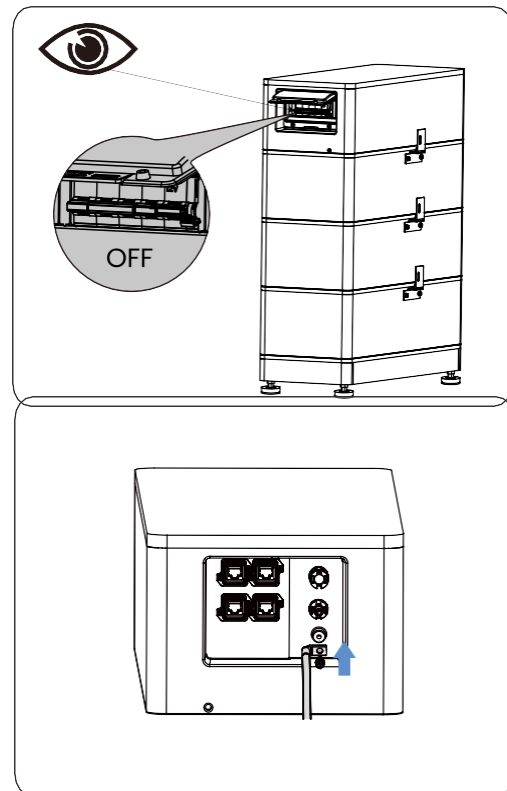

6.4. Data Cable Connection

 **QUALIFIED PERSON**

The ends of all the data cables to BMS are RJ45 connector. The RJ45 connector should be fitted into the network coupler before being plugged into corresponding ports.

6.4.1. Fit RJ45 Connector into the Coupler

The method of fitting RJ45 connector into the coupler is:

- A) Loosen the nut at the end of the coupler.
- B) Get the end of the cable without the RJ45 connector through the coupler. (If the cable has two RJ45 ends, cut the cable to make sure at least one end has no RJ 45 connector.)
- C) Fit the RJ45 connector into the bushing.
- D) Plug the assembled bushing and RJ45 connector into the coupler, and tighten the nut of the coupler. (Make sure the installation signs of the bushing and the coupler are on the same side.)

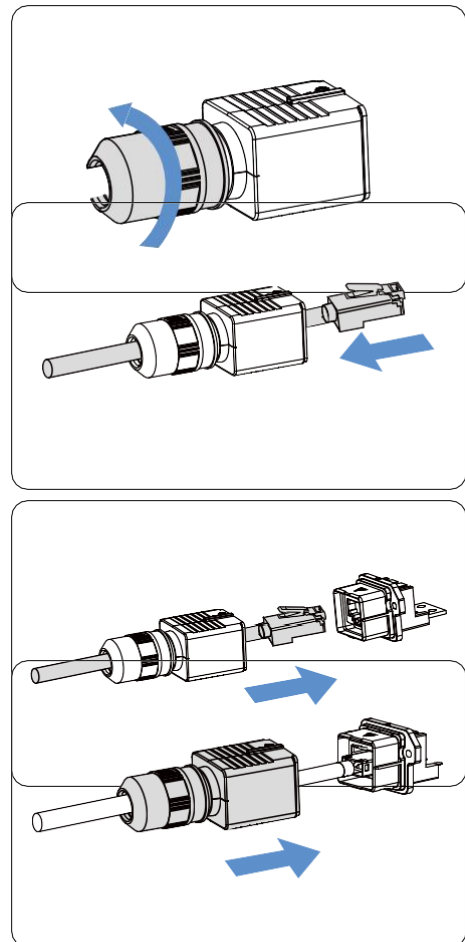

6.4.2. Connect the Data Cable to the Inverter

**Additional required materials
(not included in the scope of delivery):**

One network cable (Cat5, Cat5e or higher)

Data cable requirements:

The length and quality of the cable will affect the quality of the signal. Please observe the following cable requirements.

- Cable category: Cat5, Cat5e or higher
- Plug type: Metal Shielded RJ45 of Cat5, Cat5e or higher
- Shielding: Yes
- UV-resistant for outdoor use
- Straight-through wired cables
- Maximum cable length: 20 m

Procedure:

1. Trim the cable according to the following PIN designation of port D and also the corresponding port at the inverter. The designation of port D could be read in the table below.
2. Fit the cable with RJ45 connector in the coupler according to the method mentioned in 6.4.1.
3. Take off the dust cover on port D.
4. Plug the coupler with cable into port D.

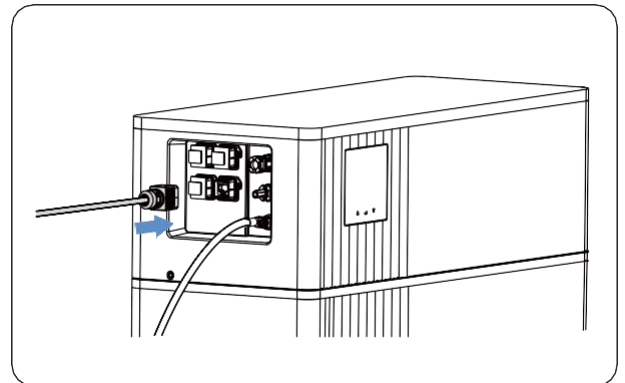

Pin number	1	2	3	4	5	6	7	8
Designation	RS485A	RS485B	EN	CAN H	CAN L	EN_GND	12 IN	12V IN_GND

6.4.3. Connect to the Router

This step is not mandatory, but strongly suggest .



Danger to life due to electric shock in case of overvoltages and if surge protection is missing

Overvoltages (e.g., in the event of a flash of lightning) can be further conducted into the building and to other connected devices in the same network via the network cables or other data cables if there is no surge protection. Touching live parts and cables results in death or lethal injuries due to electric shock.

- Ensure that all devices in the same network and the inverter are integrated into the existing surge protection.
- When laying the network cables or other data cables outdoors, it must be ensured that a suitable surge protection device is provided at the transition point of the cable from the battery system or the inverter outdoors to the inside of a building.

Additional required materials (not included in the scope of delivery):

- Network cables (Cat5, Cat5e or higher)

Data cable requirements:

The length and quality of the cable will affect the quality of the signal. Observe the following cable requirements.

- Cable category: Cat5, Cat5e or higher
- Plug type: Metal Shielded RJ45 of Cat5, Cat5e or higher
- Shielding: Yes
- UV-resistant for outdoor use
- Straight-through wired cables
- Maximum cable length: 20 m

Procedure:

1. Fit the cable with RJ45 connector in the coupler according to the method mentioned in 6.4.1.
2. Take off the dust cover on Port C.
3. Plug one side of the cable with coupler into Port C, and the other side to the LAN port of a router.

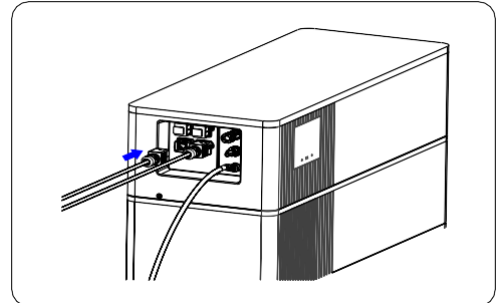

6.4.4. Parallel Connection between Towers

This step is only needed if multiple towers are to be connected in parallel.

Additional required materials (not included in the scope of delivery):

- Network cables (Cat5, Cat5e or higher)

Data cable requirements:

The length and quality of the cable will affect the quality of the signal. Observe the following cable requirements.

- Cable category: Cat5, Cat5e or higher
- Plug type: Metal Shielded RJ45 of Cat5, Cat5e or higher
- Shielding: Yes
- UV-resistant for outdoor use
- Straight-through wired cables
- Maximum cable length: 20 m

Procedure:

1. Fit the cable with RJ45 connector in the coupler according to the method mentioned in 6.4.1
2. Take off the dust covers on the OUT port of the master tower, the IN port of the last slave tower and all the IN and OUT ports in other towers.
3. Connect the OUT port of the master tower with the IN port of the first slave tower, the OUT port of the first slave tower with the IN port of the second slave tower, and so on.

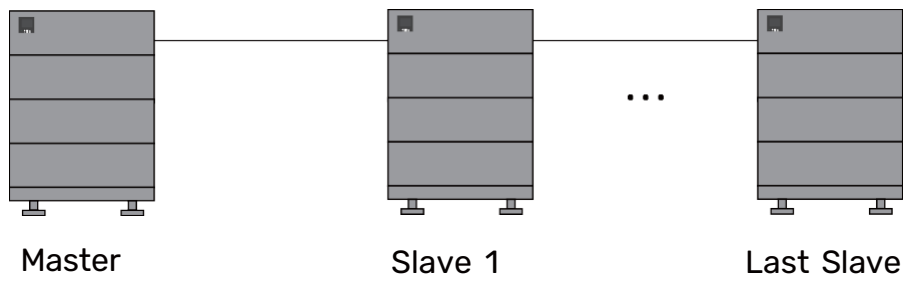
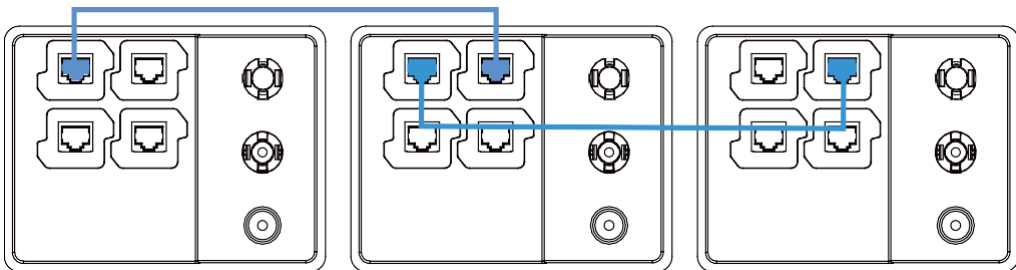

6.5. DC Connection



Danger to life due to electric shock resulting from live DC cables or connectors in the battery system

The DC cables connected to the battery system may be live. Touching the DC conductors or the live components leads to lethal electric shocks.

- Do not touch non-insulated cable ends.

When multiple towers are connected, the positive power cable length of all the battery systems should be approximately equal, and so are the negative power cables.

Please also follow the local, state, provincial, federal, or national laws, regulations, and instructions from the inverter manufacturer to connect all the DC cables.

Additional required mounting materials (not included in the scope of delivery):

Two DC power cables per tower

Procedure:

1. Assembling DC connectors

Cable requirements:

- Conductor cross-section: 6 mm². Follow the requirements of the inverter manufacturer.
- Maximum cable length: 20 m

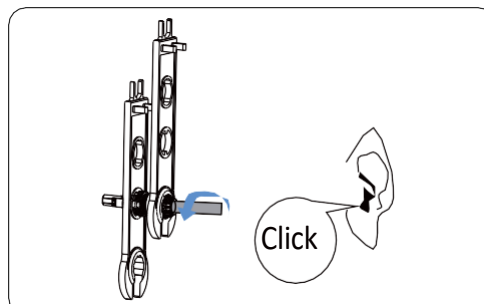
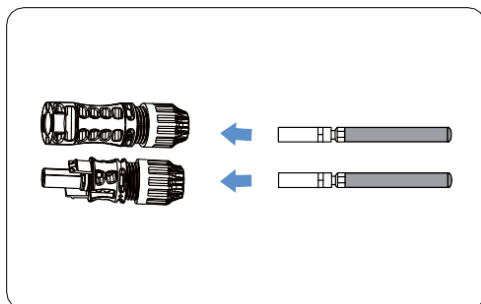
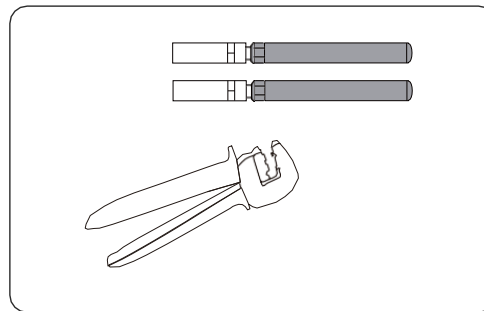
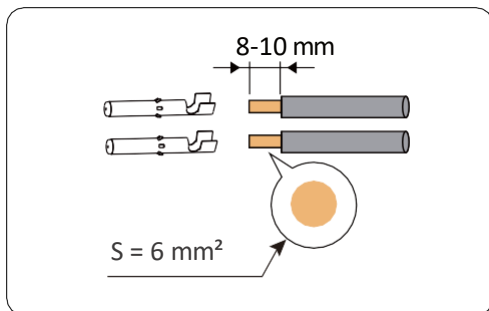

2. Plug the connectors into the corresponding DC cable ports.

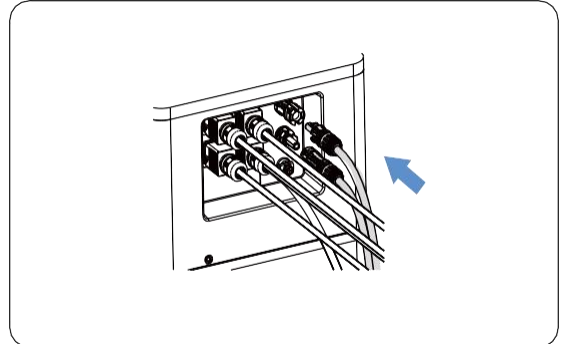

3. Cover each power cable connector with the protection sleeve.

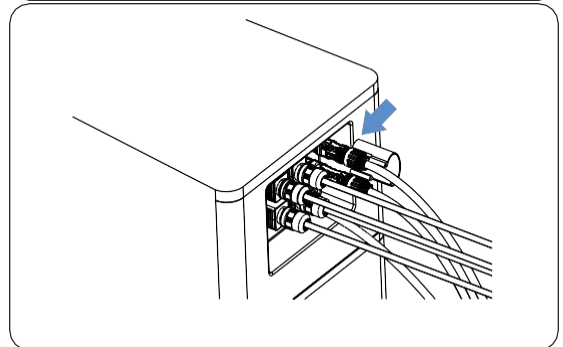

4. Fix the sleeve with the pin.

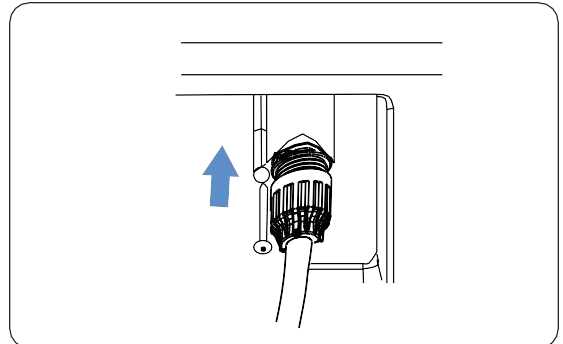

7.1. Switch on Inverter AC power Supply and Do Configuration



QUALIFIED PERSON

Requirements:

- The power cable connection between the battery system and the inverter is switched off.
- The inverter must be correctly mounted.
- All cables must be correctly connected.

Procedure:

1. Switch on the inverter.
2. Configure the inverter according to the inverter manufacturer's instructions.

7.2. Switch on the Battery System



QUALIFIED PERSON

Requirements:

- The power cable connection between the battery system and the inverter is switched off.
- The inverter must be correctly mounted.
- All cables must be correctly connected.

Procedure:

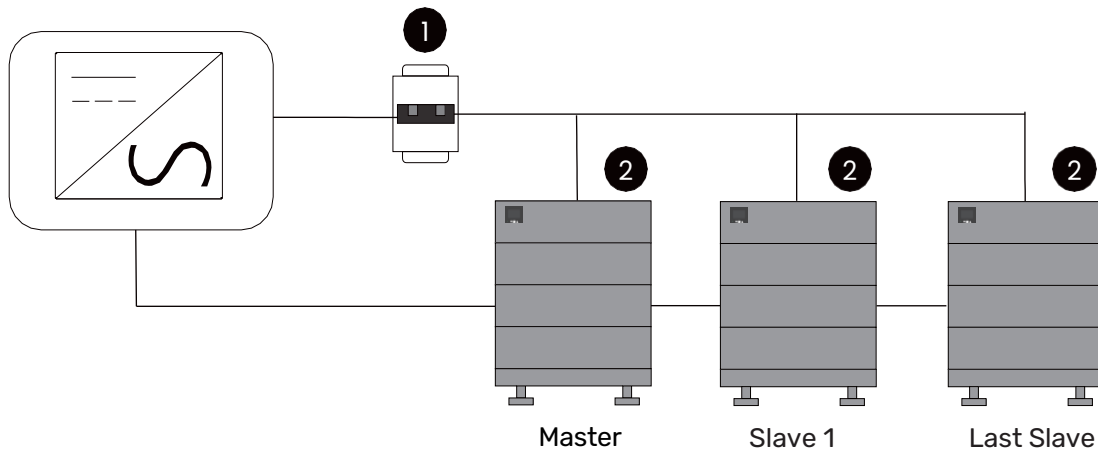

1. Switch on the air switch between the battery and inverter if there is any.
2. Open the plastic cover of the air switch in the BMS.
3. Turn on the air switch. The LCD screen will light up, and shows the status of the battery system. If there is any error, please read the Service Manual for troubleshooting.

7.3. Configure the Settings on the LCD Display

1. Terminal Res

You only need to make this setting for the master tower, and set it as "ON".

2. Parallel Res

- A) Single tower system: set it as "ON"
- B) Multiple towers system: set the master tower and the last slave tower as "ON", and all the others as "OFF".

3. End System

- A) Single tower system: set it as "ON".
- B) Multiple towers system: set the last slave tower as "ON", and all the others as "OFF".

4. Default set

Keep the default status as "ON".

7.4. Close up



QUALIFIED PERSON

Requirements:

- The battery system could operate normally. No need to switch on and off the air switch anymore

Procedure:

1. Pull down the plastic cover.
2. Tighten the two screws on the cover.

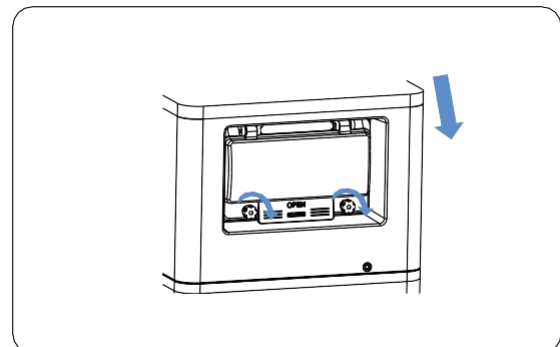

8.1. Switch on the Battery System

Battery and inverter system start sequence:

- 1) Switch on the air switch between the inverter and battery if there is any;
- 2) Switch on the air switches in all the BMS;
- 3) Switch on the inverter. ...

(The battery may not work properly if the sequence is not correct.)

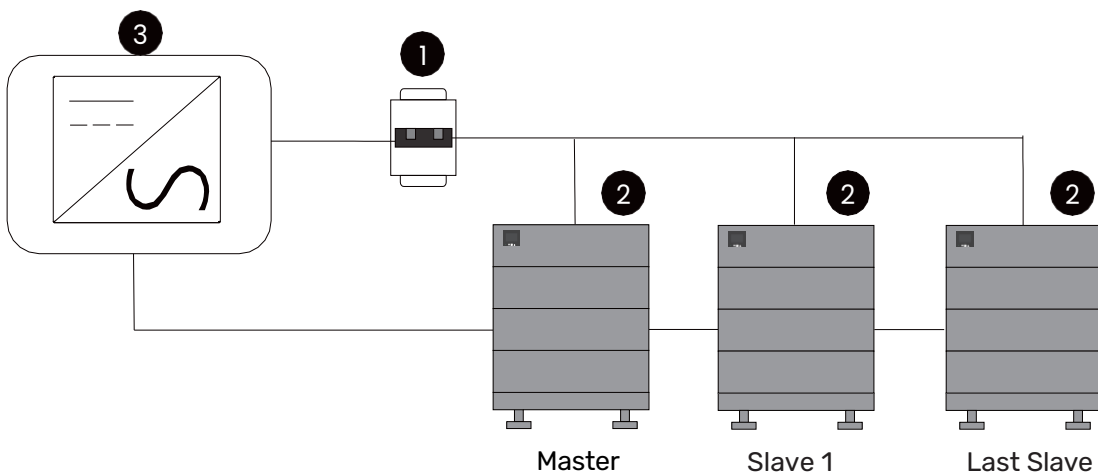

To switch on the battery system:

- 1) Loosen the two plastic screws on the air switch cover;
- 2) Open the switch cover;
- 3) Turn on the air switch.

Please make sure the air switch cover is well fixed before you leave the site.

8.2. Switch off the Battery System

Battery and inverter system switch off sequence:

- 1) Switch off the inverter;
- 2) Switch off the air switch of the BMS on the master tower. (For a multiple tower system, you only need to turn off the air switch on the master tower. The slave towers will shut off automatically in a few seconds);
- 3) Switch off the switch between the inverter and battery if there is any.

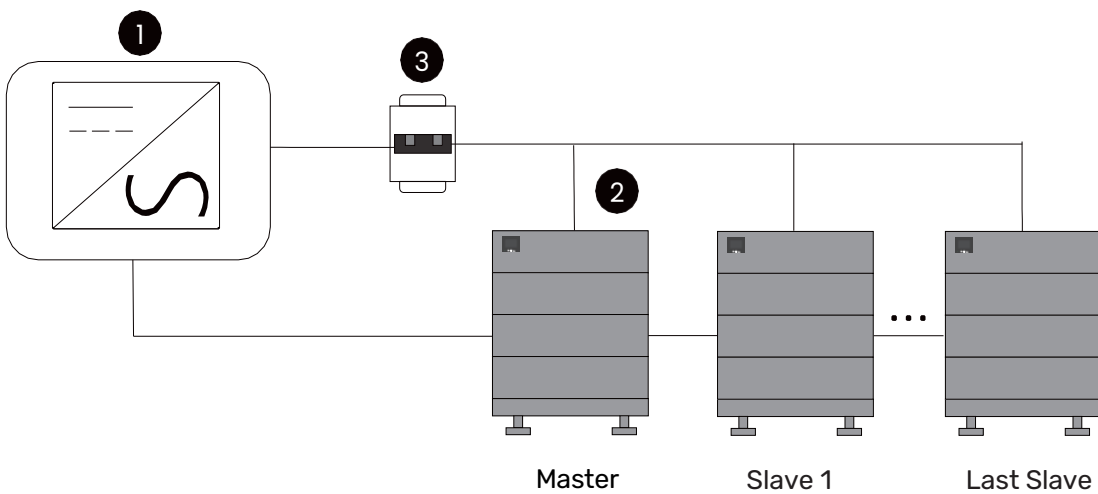

To switch off the battery tower:

- 1) Loosen the two plastic screws on the air switch cover;
- 2) Open the switch cover;
- 3) Turn off the air switch.

Please make sure the air switch cover is well fixed before you leave the site.

 **QUALIFIED PERSON**

 **DANGER**

Danger to life due to electric shock resulting from live DC cables or connectors in the battery system

The DC cables connected to the battery system may be live. Touching the DC conductors or the live components leads to lethal electric shocks.

- Do not touch non-insulated cable ends.

 **CAUTION**

Risk of injury due to the weight of the battery stack

Injuries may occur if the battery stack is lifted incorrectly or dropped while being transported or installed.

- Transport and lift the battery stack carefully. Take the weight of the battery stack into account.
- Wear suitable personal protective equipment for all work on the battery system.

Procedure:

1. Shut off the inverter.
2. Switch off the battery system.
3. Switch off the air switch between the inverter and the battery system if there is any.
4. Remove all the cables from the battery system.

A) Remove the data cable coupler

Press two sides (either left/right sides or up/down sides) of the data cable coupler at the same time, and then remove it.

B) Remove the power cable

Remove the pin on the plastic sleeve with a screwdriver.

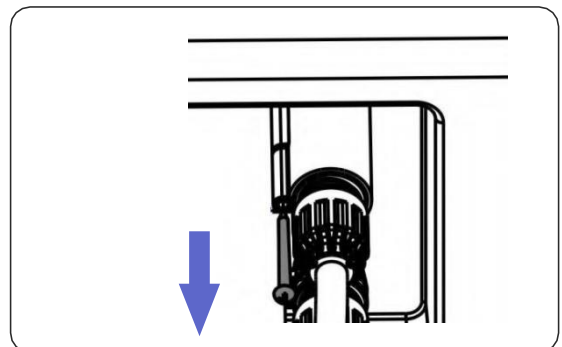

Put the power cable connector tool (PV-MS-PLS) under the connector.

Remove the power cable from the BMS.

C) Remove the grounding cable.

D) Plug the dust covers into the ports.

5. Remove the screws between BMS and the battery stack. And then lift the BMS from the tower.

6. Loosen the bolt on the hanger attached to the wall, remove the hanger and then remove the stack from the tower.

If the battery system is to be stored or shipped, pack the system. Use the original packaging or packaging that is suitable for the weight and dimensions of the system.

Dispose of the battery system in accordance with the locally applicable disposal battery regulations.

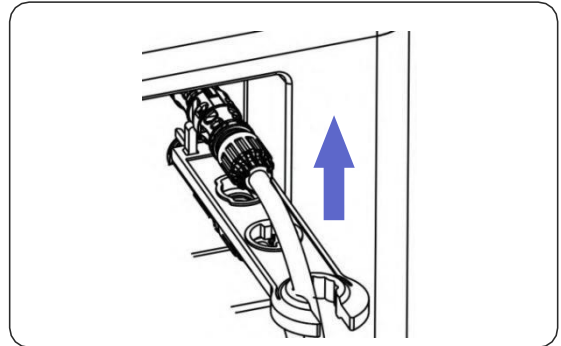

The SOC of the existing system and the stack to be added should be similar before the stack adding on the existing system.

Please keep in mind that the quantity of the stacks in each tower cannot exceed the limitation.

Procedure:

1. Charge or discharge the existing system to a SOC of around 30%. (Note: new stacks have a SOC of around 30%.)
2. Shut off the inverter.
3. Switch off the battery system.
4. Switch off the air switch between the inverter and the battery system if there is any.
5. Loosen the screw between the BMS and battery stack, and then take the BMS off.
6. Add the new stack on top of other battery stacks, and fix it on the wall.
7. Put BMS back on top.
8. Switch on the switch between the inverter and the battery system if there is any.
9. Switch on the battery system
10. Check the settings on the LCD.
11. Switch on the inverter.

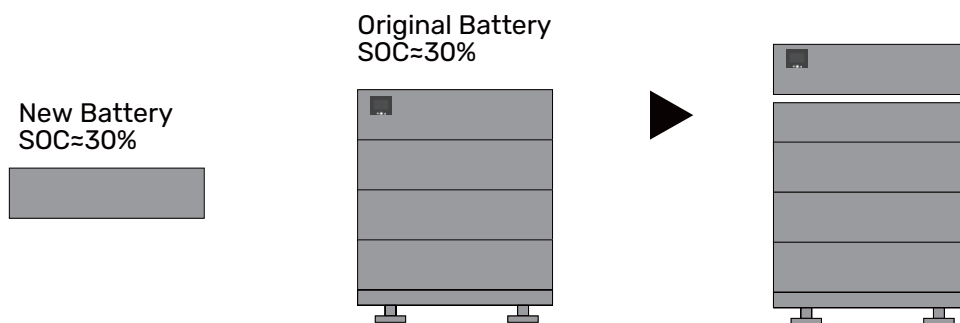

11. Troubleshooting

Please refer to Sunbatt Battery Service Manual for troubleshooting. The latest version is available at the website: www.sunbatt.eu

Cleaning

It is recommended that the battery system be cleaned periodically. If the enclosure is dirty, please use a soft, dry brush or a dust collector to remove the dust. Liquids such as solvents, abrasives, or corrosive liquids should not be used to clean the enclosure.

Maintenance

The battery stack should be stored in an environment with a temperature range between $-10\text{ }^{\circ}\text{C}$ ~ $+55\text{ }^{\circ}\text{C}$, and charged regularly according to the table below with no more than 0.5 C (C-rate is a measure of the rate at which a battery is discharged relative to its maximum capacity) to the SOC of 30% after a long time of storage.

Storage environment temperature	Relative humidity of the storage environment	Storage time	SOC
Below $-10\text{ }^{\circ}\text{C}$	/	Not allowed	/
$-10\text{--}30\text{ }^{\circ}\text{C}$	5%~70%	≤ 12 months	$25\% \leq \text{SOC} \leq 60\%$
$30\text{--}35\text{ }^{\circ}\text{C}$	5%~70%	≤ 6 months	$25\% \leq \text{SOC} \leq 60\%$
$35\text{--}55\text{ }^{\circ}\text{C}$	5%~70%	≤ 3 months	$25\% \leq \text{SOC} \leq 60\%$
Above $55\text{ }^{\circ}\text{C}$	/	Not allowed	/

13. Disposal of the Battery System

Disposal of the system must comply with the local applicable disposal regulations for electronic waste and used batteries.

- Do not dispose of the battery system with your household waste.
- Avoid exposing the batteries to high temperatures or direct sunlight.
- Avoid exposing the batteries to high humidity or corrosive atmospheres.
- For more information or to arrange a collection please contact Sunbatt **service team** (see contact information in Chapter 15).

14. Technical Data

Sunbatt Peak

	2	3	4	5
Number of Stacks	2	3	4	5
Usable Energy (kWh)	5.52	8.28	11.04	13.80
Max Output Current (A)	25	25	25	25
Peak Output Current (A)	50 (5s)	50 (5s)	50 (5s)	50 (5s)
Nominal Voltage (V)	204.8	307.2	409.6	512
Operating Voltage Range (V)	172.8~233.6	259.2~350.4	345.6~467.2	432~584
Dimensions (H/W/D) (mm)	625* 650 *260	800* 650 *260	975* 650 *260	1150* 650 *260
Weight (kg)	90	125	160	195
Battery Designation	IFpP/22/101/145/32S/M/-10+55/90			

Sunbatt Flex

	3	4	5	6	7	8
Number of Stacks	3	4	5	6	7	8
Usable Energy (kWh)	9.6	12.8	16.0	19.2	22.4	25.6
Max Output Current (A)	30	30	30	30	30	30
Peak Output Current (A)	50 (5s)	50 (5s)	50 (5s)	50 (5s)	50 (5s)	50 (5s)
Nominal Voltage (V)	192	256	320	384	448	512
Operating Voltage Range (V)	162~219	216~292	270~365	324~438	378~511	432~584
Dimensions (H/W/D) (mm)	800* 650 *260	975* 650 *260	1150* 650 *260	1325* 650 *260	1500* 650 *260	1675* 650 *260
Weight (kg)	129.5	166	202.5	239	275.5	312
Battery Designation	IFpP/29/149/119/20S/M/-10+55/90					

General Parameters

Operation Temperature	-10 ~ 55 °C
Protection Rating	IP65
Round-trip Efficiency	≥ 95%
Certification & Compliance	IEC62619/IEC62477 /CEC/CE/UN38.3
Applications	ON Grid /ON Grid+Backup / OFF Grid
Warranty	10 Years

15. Contact Information

Sunbatt Europe SL



info@sunbatt.eu



0034 689 416 541



Arboleda 18, 28031, Madrid, Spain



www.sunbatt.eu